

PRISMA

P A R M A I T A L Y



checkweigher
35T3 pharma





discover
all the details
on our web-site!

Technical Specifications

Weighing range	up to 1500 g
Display division	from 0,1 g
Throughput	up to 120 ppm
Accuracy*	from $\pm 0,1$ g
Pneumatic supply	0,6 Mpa
Air consumption (for ejection)	1 NI
Power supply	380V three phase 50/60Hz with ground and neutral
Power consumption	700 W
Mirror finishing of metal parts	Stainless Steel IP54
Climatic environment	from 5°C up to +40°C non-condensing (closed)

*depending on the weight, dimensions and type of product

Electronics

T3



- Digital electronics with PC Mainboard mini-ITX
- 10,4" TFT color display with touch screen panel
- Windows 10 IoT operating system
- 200 storable product programs

D3



- Digital electronics with alphanumeric graphic display
- 100 storable product programs

Equipment

- Electronic self-calibration device
- Conformity with standards ISO - FDA - HACCP - GMP - CE
- 3 levels password access protection
- Wind-prevention tunnel
- Separated electronic equipment
- Mobile average function
- 2 RS232 serial ports
- Production data management in conformity with the standards in force

Optional

- Ejection systems
- Reject management systems
- Alarms notification
- 24-columns panel printer
- USB interface
- Ethernet interface for Industry 4.0 compliance
- Products programs memory expansion
- Feed-back function
- FAT/SAT, IQ/OQ validations, CFR21 part 11

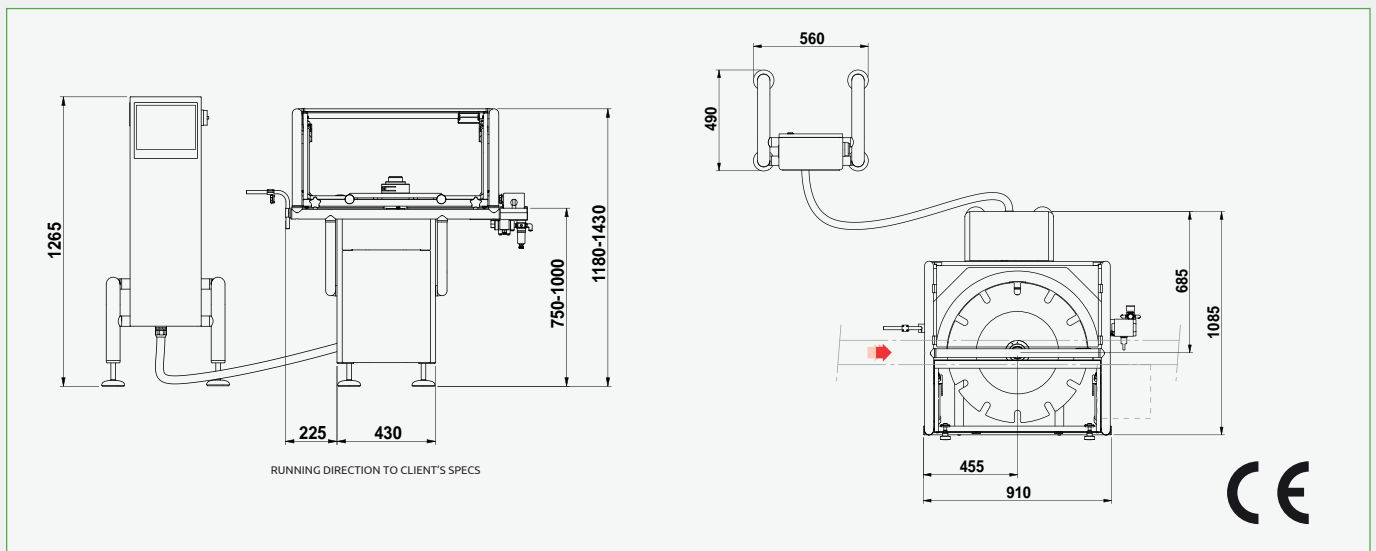

The manufacturer reserves the right to change the product specifications without notice. The image and the drawing are indicative of one of the possible configurations of the machine.