

checkweigher
01T3 with screw





discover all the details on our web-site!



Technical Specifications

Weighing range	up to 1600 g
Display division	from 0,1 g
Linear speed	up to 100 m/min
Throughput	up to 500 ppm
Accuracy*	from $\pm 0,1$ g
Pneumatic supply	0,6 Mpa
Air consumption (for ejection)	1 NI
Power supply	230V 50/60Hz single phase
Power consumption	800 W
Mirror finishing of metal parts	Stainless Steel IP54
Climatic environment	from 5°C up to +40°C non-condensing (closed)

*depending on the weight, dimensions and type of product

Electronics

T3



- Digital electronics with PC Mainboard mini-ITX
- 10,4" TFT color display with touch screen panel
- Windows 10 IoT operating system
- 200 storable product programs

D3



- Digital electronics with alphanumeric graphic display
- 100 storable product programs

Equipment

- Screw on infeed conveyor
- Conformity with standards ISO - FDA - HACCP - GMP - CE
- Wind-prevention tunnel
- Electronic self-calibration device
- 3 levels password access protection
- Mobile average function
- 2 RS232 serial ports
- Production data management in conformity with the standards in force

Optional

- Ejection systems
- Reject management systems
- Outfeed tangential belts
- 24-columns panel printer
- Special conveyors
- Separated electronic equipment
- Alarms notification
- USB interface
- Ethernet interface for Industry 4.0 compliance
- Products programs memory expansion
- Feed-back function
- FAT/SAT, IQ/OQ validations, CFR21 part 11
- MID Certification

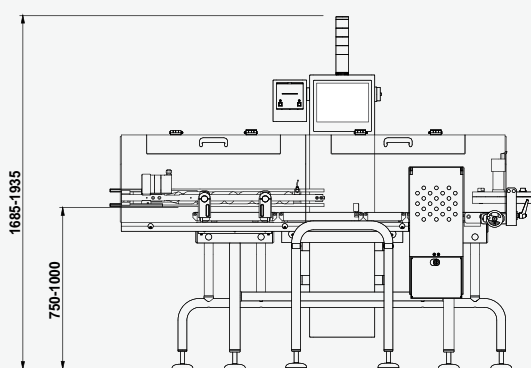

RUNNING DIRECTION TO CLIENT'S SPECS

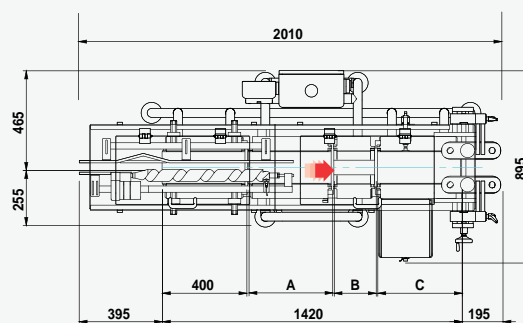

Plates configuration		
Infeed A	Weighing B	Outfeed C
400	200	400
500	100	400



The manufacturer reserves the right to change the product specifications without notice. The image and the drawing are indicative of one of the possible configurations of the machine.